



Equipment for the Concrete Products Industry

01 · **ABOUT POYATOS** .....4

02 · **HISTORY** .....6

03 · **INTERNATIONAL** .....8

04 · **VANGUARD** .....10

05 · **CONCRETE PRODUCTION MACHINES** .....12

06 · **AUTOMATIC STATIONARY PRODUCTION MACHINES** .....14

07 · **PRIMA AND PRIMA L** .....16

08 · **SYNCRO** .....18

09 · **HIGHLY PRODUCTIVE STATIONARY PRODUCTION MACHINES** ..20

10 · **UNIVERSAL** .....22

11 · **NOVABLOC** .....24

12 · **MEGABLOC** .....28

13 · **CONCRETE BATCHING PLANTS** .....30

14 · **MACHINERY FOR SPECIAL PRODUCTS AND SURFACE TREATMENTS** ..32

15 · **TAILOR MADE SOLUTIONS** .....34

16 · **CONCRETE PRODUCTS** .....36

17 · **AFTER SALES SERVICE** .....38



**Poyatos Export S.A**  
Telf. +34 958 46 69 90  
Polígono Industrial Juncaril.  
Calle Loja 119, 18220 Albolote  
Granada - España



### ***Poyatos***

*is a leading international provider of machinery and systems for the concrete products industry. We supply turnkey solutions for semi automatic and fully automated plants, including batching, handling and packaging systems.*

First Factory  
1971 - 1980



Second Factory  
1981 - 2000



Third Factory  
Since 2001



*Our company is manufacturing equipment for the concrete products industry since 1971*

POYATOS is a family owned enterprise, located in Granada (Spain). With more than 30.000 sq.m (325.000 sq.ft) under roof, our factory is equipped with the most advanced technology.

All important manufacturing processes are kept in house and are completely automated, using robotic and numerically controlled machinery. Where we have to buy outside (such as motors, hydraulic valves, etc.) we only use suppliers of first-class renown. Our cutting edge production equipment, coupled with "lean" manufacturing techniques allows for fast and accurate throughput with continuous quality control. It also results in superior product, manufactured at very low cost. We pass all these benefits on to our clientele.



*Poyatos, a global supplier with customers in more than 80 countries across all five continents*

With a vast experience since 1971 and more than 1.000 plants installed worldwide, (a large percentage of these sold to repeat customers), POYATOS today is a truly international company providing turn key projects meeting the needs of every market. We have a presence on all 5 continents and the capability to provide service to our clientele around the clock, irrespective of their location.

## *An expert and qualified staff*

One of POYATOS biggest assets is our highly qualified, experienced and dedicated work force which include a great number of mechanical, electrical and electronic engineers.

This expertise has enabled us to design and develop a multitude of patents which have flowed into our product designs which are entirely manufactured at our workshop, including the electrical and control panels, what allows us to pre-test the equipment before delivery and to provide a state of the art after-sales service.

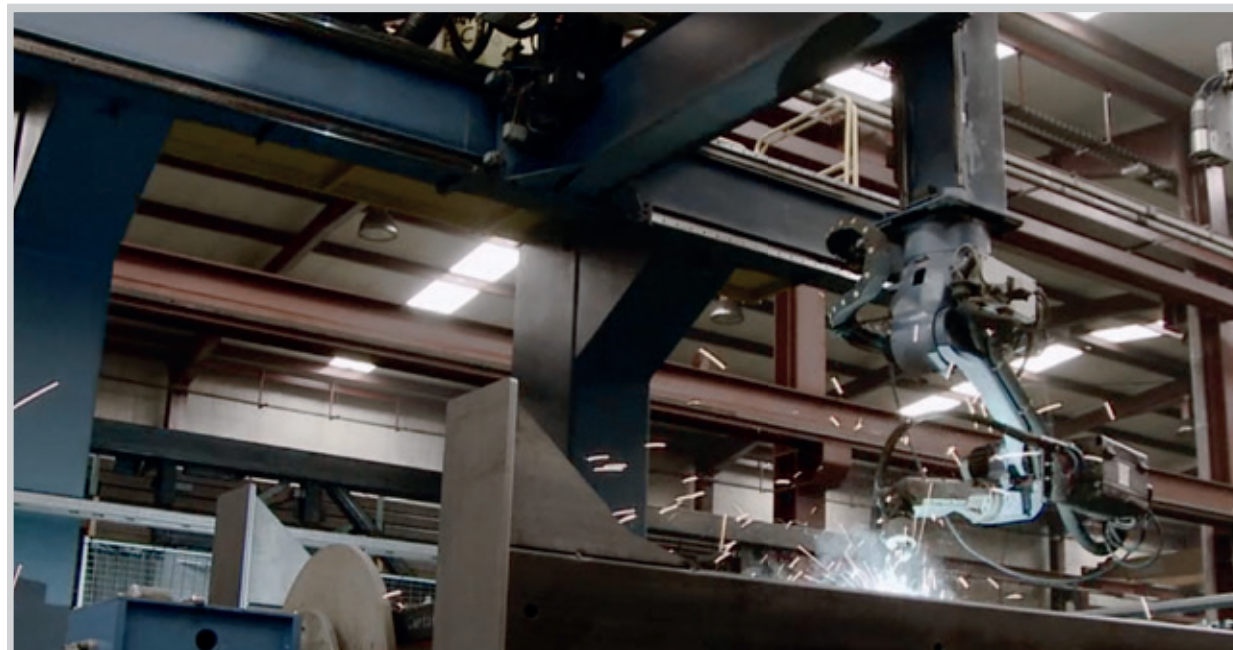

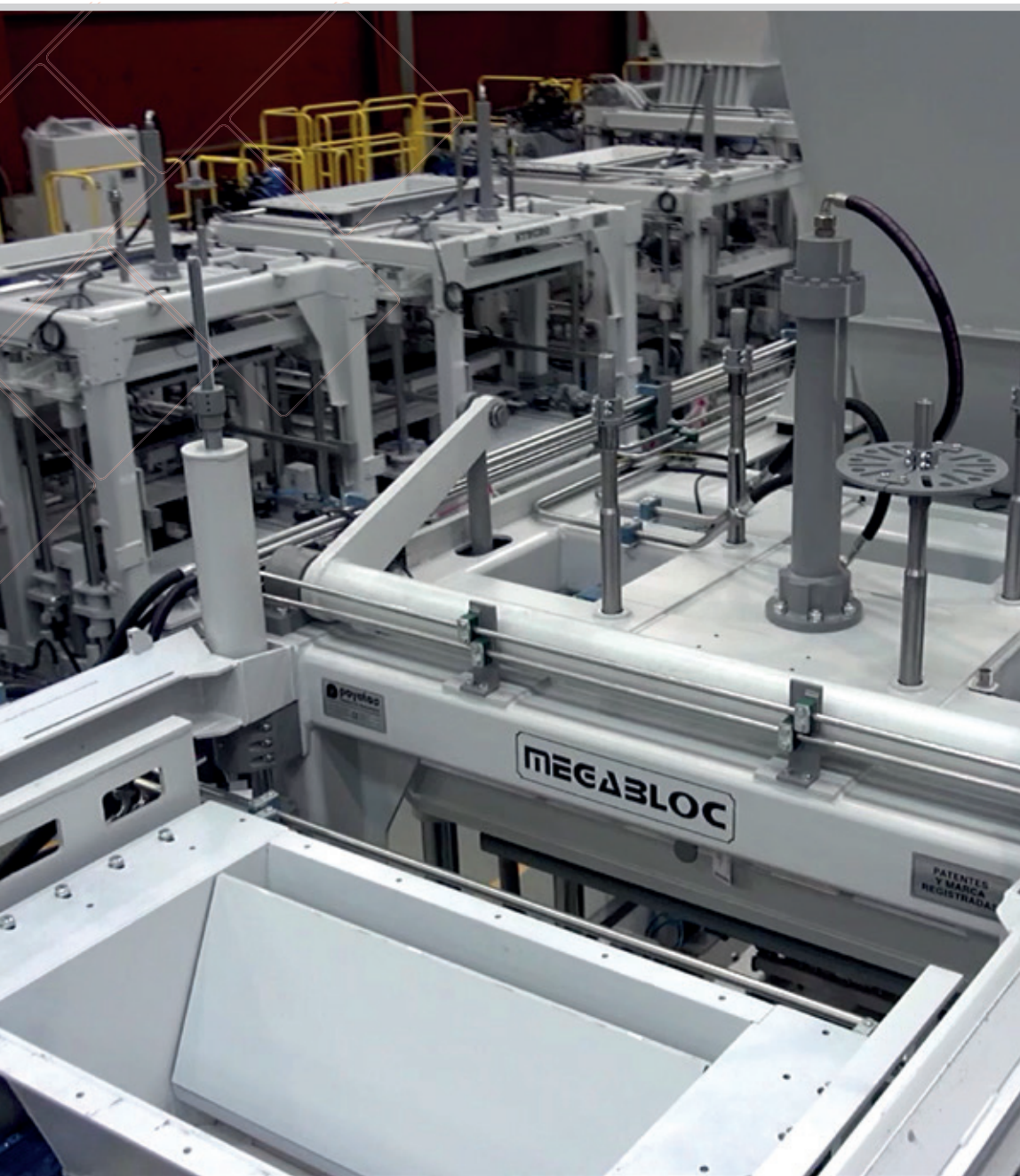

**Poyatos**  
product design and fabrication  
under our own patents

We produce a wide range of production machinery, from semi to fully automatic, and with production capabilities ranging from 65 to 400 sq.m (700 to 4300 sq.ft.) of flat product or 800 to 4.500 standard size blocks per hour.

Our 5 main machine models can run with steel, plastic or wood production boards and come each in varying sizes and levels of sophistication and automation. Alongside the machines we supply a range of auxiliary systems (curing, splitting, transporting, packaging etc.) which can be tailored to the specific needs of each client.

The modular concept of our equipment allows producers to up-grade their production in steps, according to market needs and budgetary requirements, while simultaneously reducing their production and amortization costs.

Ease of handling and versatility are one of the great hallmarks of the POYATOS brand.

MODEL	MAXIMUM* PALLET SIZE (mm)	USEFUL PRODUCTION AREA	CYCLE TIME** (sec.)	CYCLE PARTS			PRODUCTION PER HOUR***		
				PAVERS 10X20 (pcs)	BLOCKS 15X20X40 6"	BLOCKS 20X20X40 8"	PAVERS (single layer) 10X20 (sqm)	BLOCKS 15X20X40	BLOCKS 20X20X40
Automatic Stationary Production Machines									
<b>PRIMA</b>	1.080 x 680	1.020 x 640	18	27	6	5	108	1.200	1.000
<b>SYNCRO</b>	1.400 x 750	1.300 x 690	16	36	12	9	162	2.700	2.025
Highly Productive Stationary Production Machines									
<b>UNIVERSAL</b>	1.400 x 750	1.300 x 690	13	36	12	9	199	3.323	2.492
<b>UNIVERSAL 900</b>	1.400 x 900	1.300 x 850	14	42	14	12	216	3.600	3.086
<b>NOVABLOC</b>	1.400 x 750	1.300 x 690	12	36	12	9	216	3.600	2.700
<b>NOVABLOC 900</b>	1400 x 900	1.300 x 850	13	42	14	12	233	3.877	3.323
<b>MEGABLOC</b>	1.400 x 1.350	1.300 x 1.300	14	66	21	18	370	5.400	4.629

\* The size of the production pallets (wooden, steel or plastic) may be tailored according to the requests of each project.  
 \*\* The cycle time is for guidance only and may vary depending on the type of product, quality of the aggregates, staff and other factors related to the production.  
 \*\*\* The hourly production is for guidance only and it is calculated at 100% of the capacity of each machine.

KEY

01	Concrete block making machine
02	Elevator
03	Lowerator
04	Automatic cuber
05	Dosage unit
06	Aggregates collector belt
07	Mixer
08	Screw conveyor for cement
09	Silos for cement
10	Lifting conveyor belt for concrete

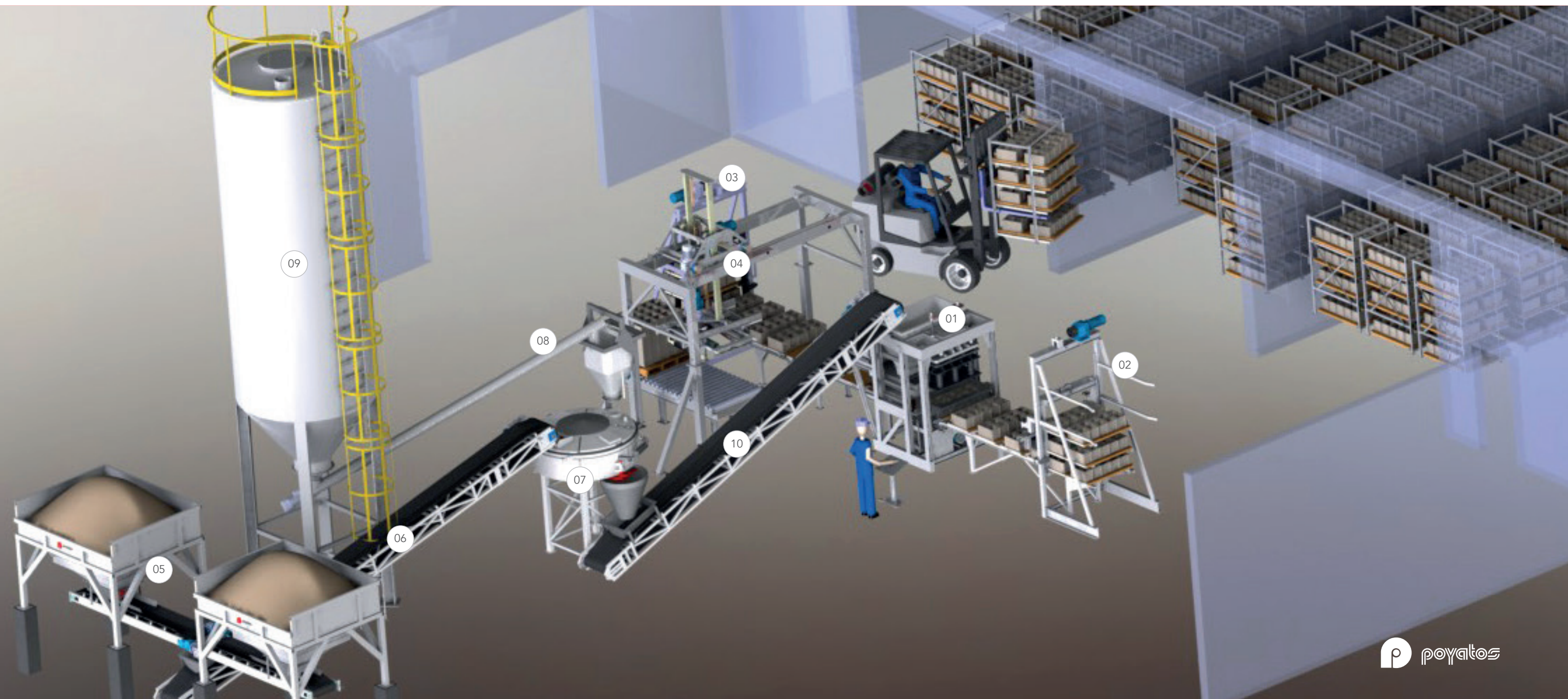



**PRIMA,**  
the budget machine for  
starting your concrete business



Our PRIMA is the ideal low budget solution for entrepreneurs wanting to get a start in the industry. It enables the operator to manufacturing quality concrete products at an industrial level and is also ideal for someone wishing to produce special products on a limited scale.

As a stationary single-layer machine (double layer is an option if required), it offers considerable productivity, is robust and very user friendly, requires very little maintenance and is easy and fast to install.

Both batching as well as the actual production are fully automated processes. Once that the products are de-molded on either wooden, plastic or steel production boards, they are transported by an operator to the curing chamber by means of a trolley; packaging is done manually after the curing process has been completed.

MODEL	MAXIMUM* PALLET SIZE (mm)	USEFUL PRODUCTION AREA	CYCLE TIME** (sec.)	CYCLE PARTS			PRODUCTION PER HOUR***		
				PAVERS 10X20 (pcs)	BLOCKS 15X20X40 6"	BLOCKS 20X20X40 8"	PAVERS (single layer) 10X20 (sqm)	BLOCKS 15X20X40 6"	BLOCKS 20X20X40 8"
PRIMA	1080 x 680	1020 x 640	18	27	6	5	108	1200	1000

\* The size of the production pallets (wooden, steel or plastic) may be tailored according to the requests of each project.  
 \*\* The cycle time is for guidance only and may vary depending on the type of product, quality of the aggregates, staff and other factors related to the production.  
 \*\*\* The hourly production is for guidance only and it is calculated at 100% of the capacity of each machine.

**PRIMA L,**  
an upgraded line with a  
higher automation level

Our PRIMA-L line includes the PRIMA machine plus an elevator and lowerator to ease the transfer of the production boards and green product to the curing rooms by means of a rack system. A manual clamp or automatic cuber is also part of the package and will assist in cubing and packaging processes. Equipment to manufacture products with double layer is available if required.

The PRIMA-L line has been designed to reduce the need for manpower, lower production cost and increase productivity of the installation.



**Technical Data:**

- Product height: 25 - 250 mm (1" - 10").
- Plant area: 700 sq.m.
- Number of operators: 3 - 4.
- Control panel with PLC, digital console and data storage.

**Vibration:**

- Single vibrating table.
- Lubrication by permanent oil bath (minimum maintenance).
- Maximum vibration force: 47,6 kN.
- Power: 7.5 kW.

**Hydraulic Unit:**

- Water cooling.
- Power: 11 kW.

**Technical Data:**

- Product height: 25 - 300 mm (1" - 12").
- Plant area: 1.000 sq.m.
- Number of operators: 2 - 3.
- Control panel with PLC and touch screen terminal permitting storage of and access to all production variables as well as historical production data.

**Vibration:**

- One vibrating table, synchronized and frequency controlled.
- Lubrication by permanent immersion in oil for minimum maintenance.
- Maximum vibration force: 71,5 kN.
- Power: 20 HP - 25 HP (15 kW - 18,5 kW).

**Hydraulic Unit:**

- Water cooling.
- Power: 30 HP (22 kW).

## SYNCRO, a robust machine with multiple options to configure the production line

Our SYNCRO can run with either wooden, plastic or steel production boards in sizes ranging from 1200 x 550 mm (47 x 22") to 1400 mm x 900 mm (55" x 35").

SYNCRO is a stationary, automatic machine which is both robust and user-friendly to operate and maintain. It offers significant productivity to the operator. This machine can also be equipped with face mix.

The plant layout can be configured as in-line system or in U-shape; it combines with an elevator and lowerator of 5 levels for easy handling and transport of the loaded production boards by forklift. To expedite product packaging, a pneumatic or electronic cuber can be installed. Opting for a plant layout in U-shape also allows adding a pallet turnover device plus - if needed - a lubricating station.



MODEL	MAXIMUM* PALLET SIZE (mm)	USEFUL PRODUCTION AREA	CYCLE TIME** (sec.)	CYCLE PARTS			PRODUCTION PER HOUR***		
				PAVERS 10X20 (pcs)	BLOCKS 15X20X40 6"	BLOCKS 20X20X40 8"	PAVERS (single layer) 10X20 (sqm)	BLOCKS 15X20X40 6"	BLOCKS 20X20X40 8"
SYNCRO	1400 x 750	1300 x 690	16	36	12	9	162	2700	2025

\* The size of the production pallets (wooden, steel or plastic) may be tailored according to the requests of each project.

\*\* The cycle time is for guidance only and may vary depending on the type of product, quality of the aggregates, staff and other factors related to the production.

\*\*\* The hourly production is for guidance only and it is calculated at 100% of the capacity of each machine.

KEY			
01	Concrete block making machine	08	Magazine of pallets
02	Equipment for face mix concrete	09	Dosing group
03	Elevator	10	Complete skip hoist
04	Lowerator	11	Mixer
05	Finger car	12	Screw conveyor for cement
06	Automatic cuber	13	Silos for cement
07	Rollers track	14	Elevating belt for concrete

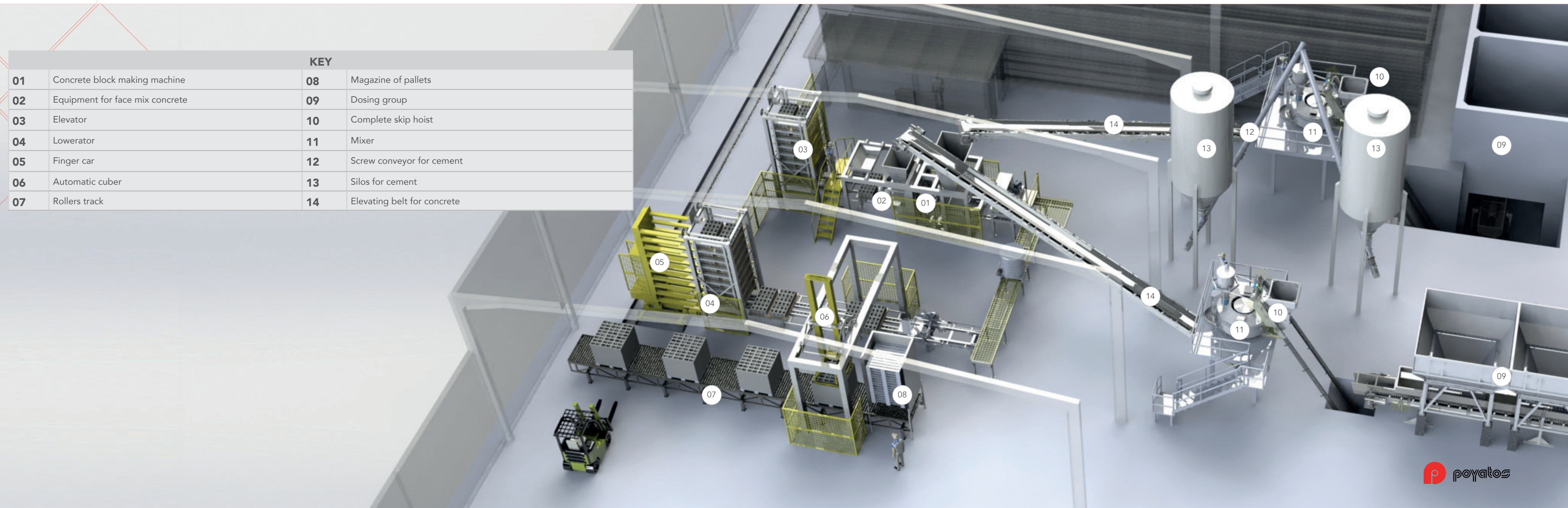

**Technical Data:**

- Product height: 25 - 300 mm (1" - 12"), choice 400 mm (16").
- Production area required (for both equipment and curing chambers): 1500 sq.m. (16 200 sq.ft.).
- Customized software program:
  - Touch screen for easy, visually aided control of equipment and production.
  - Memory bank for easy storage and retrieval of production parameters and historical data.
  - Online support service, allowing for remote access and trouble shooting.

**Vibration:**

- One vibrating table.
- Accionamiento por un solo motor (Patentada).
- Lubricated by permanent oil-bath immersion (minimum maintenance).
- Variable vibration (frequency and amplitude control) with 80 kN max. vibratory force.
- Power: 30 HP (22 kW).

**Hydraulic Unit:**

- Air cooled.
- Power: 30 HP (22 kW).



## UNIVERSAL, a fully automated line requiring minimum manpower and maintenance

Our UNIVERSAL line is our basic proposal for a mass production plant that can be run and monitored by only one operator as the whole production process is fully automated and computerized under a customized and user-friendly software program.

The UNIVERSAL is a very streamlined line, with low energy consumption and easy to operate and service. The production machine can run with either wooden, steel or plastic boards ranging in dimensions from 1200 x 550 mm (47 x 22") to 1400 x 900 mm (55 x 35") and has a synchronised, patented vibration system that had proved along the years to be extremely reliable and efficient.

An automatic finger car does the handling and a rotating platform is optional. The line is also equipped with an automatic, electronically controlled high speed cuber supported by two columns. If needed a vacuum system (suitable for stacking thin product) as well as a manually driven or automated buffer system for the production boards can be added to the line.

This machine can also run with face-mix.

MODEL	MAXIMUM* PALLET SIZE (mm)	USEFUL PRODUCTION AREA	CYCLE TIME** (sec.)	CYCLE PARTS			PRODUCTION PER HOUR***		
				PAVERS 10X20 (pcs)	BLOCKS 15X20X40 6"	BLOCKS 20X20X40 8"	PAVERS (single layer) 10X20 (sqm)	BLOCKS 15X20X40 6"	BLOCKS 20X20X40 8"
UNIVERSAL	1.400 x 750	1.300 x 690	13	36	12	9	199	3.323	2.492
UNIVERSAL 900	1.400 x 900	1.300 x 850	14	42	14	12	216	3.600	3.086

\* The size of the production pallets (wooden, steel or plastic) may be tailored according to the requests of each project.

\*\* The cycle time is for guidance only and may vary depending on the type of product, quality of the aggregates, staff and other factors related to the production.

\*\*\* The hourly production is for guidance only and it is calculated at 100% of the capacity of each machine.

**Technical Data:**

- Product height: 25 - 300 mm (1" - 12"), choice 400 mm (16").
- Production area required (for both equipment and curing chambers): 1500 sq.m. (16 200 sq.ft.)
- Customized software program:
  - Touch screen for easy, visually aided operation control.
  - Memory bank for easy storage and retrieval of production parameters and historical data.
  - Online support service, allowing for remote, secure, access and trouble shooting by the support team.

**Vibration:**

- One vibrating table.
- Lubrication by permanent immersion in oil bath (minimum maintenance).
- Variable vibration (Frequency and amplitude); Max. force: 98 kN.
- Power: 40 HP (30 kW).

**Hydraulic Unit:**

- Air cooled.
- Power: 30 HP (22 kW).

**CYCLE PARTS****PRODUCTION PER HOUR\*\*\***

MODEL	MAXIMUM* PALLET SIZE (mm)	USEFUL PRODUCTION AREA	CYCLE TIME** (sec.)	CYCLE PARTS			PRODUCTION PER HOUR***		
				PAVERS 10X20 (pcs)	BLOCKS 15X20X40 6"	BLOCKS 20X20X40 8"	PAVERS (single layer) 10X20 (sqm)	BLOCKS 15X20X40 6"	BLOCKS 20X20X40 8"
NOVABLOC	1.400 x 750	1.300 x 690	12	36	12	9	216	3.600	2.700
NOVABLOC 900	1400 x 900	1.300 x 850	13	42	14	12	233	3.877	3.323

\* The size of the production pallets (wooden, steel or plastic) may be tailored according to the requests of each project.

\*\* The cycle time is for guidance only and may vary depending on the type of product, quality of the aggregates, staff and other factors related to the production.

\*\*\* The hourly production is for guidance only and it is calculated at 100% of the capacity of each machine.

## NOVABLOC, a fully automatic production line with our patented modular vibration system

An automatic finger car does the handling and a rotating platform is optional. The line is also equipped with an automatic, electronically controlled high speed cuber supported by two columns. If needed a vacuum system (suitable for stacking thin product) as well as a manually driven or automated buffer system for the production boards can be added to the line.

This machine can also run with face-mix.

The NOVABLOC machine is equipped with our modular, patented, vibration system. It consists of two synchronized vibrator shafts, turning in the same direction and driven by one motor. Both shafts, with two eccentric weights, are constantly rotating at 1500 RPM. Vibration is created by the relative position of the weights to each other.

This system has the following advantages:

- Energy savings due to no stopping/starting of the motor.
- Reduced cycle time (appr. 2 seconds per cycle).
- Instant vibration stop prevents segregation of raw materials.
- Reduced maintenance.
- Use of one standard, maintenance free motor, 30 HP (22 kW) to 1500 RPM.
- Adjustment of both vibration amplitude and frequency by push of a button.

Our modular vibration system is extremely reliable, historically proven, fast and efficient. It is easy to operate and needs minimal maintenance.

## NOVABLOC DRAWING KEY

<b>A1</b>	Vibro-compressing press model Novabloc	<b>1</b>	Dosing group
<b>A2</b>	Magazine injector of pallets	<b>2</b>	Complete skip hoist
<b>B1</b>	Conveyor of pallets from press to elevator	<b>3</b>	Mixer
<b>B2</b>	Cleaning brush	<b>4</b>	Platform and holding frame
<b>B3</b>	Elevator of 10 levels for 2 pallets each	<b>5</b>	Screw conveyor for cement
<b>B4</b>	Elevator of 10 levels for 2 pallets each	<b>6</b>	Cement weighting scale
<b>B5</b>	Conveyor of pallets (for 2)	<b>7</b>	Water dosing
<b>B6</b>	Brush to clean pallets	<b>8</b>	Elevating belt for concrete
<b>B7</b>	Pallets turning device	<b>9</b>	Control panel
<b>B8</b>	Injector of pallets	<b>10</b>	Silos for cement
<b>B9</b>	Lubricator of pallets	<b>11</b>	Aggregates dosing unit (face mix)
<b>C</b>	Finger car	<b>12</b>	Complete skip hoist set (face mix)
<b>D</b>	Automatic cuber	<b>13</b>	Planetary mixer (face mix)
<b>E</b>	Rollers track	<b>14</b>	Mixer platform (face mix)
<b>F</b>	Magazine of pallets	<b>15</b>	Cement screw conveyor (face mix)
<b>G1</b>	Control panel	<b>16</b>	Cement weighing scale (face mix)
		<b>17</b>	System for automatic dosing of water (face mix)
		<b>18</b>	Face mix mud belt
		<b>19</b>	Control desk

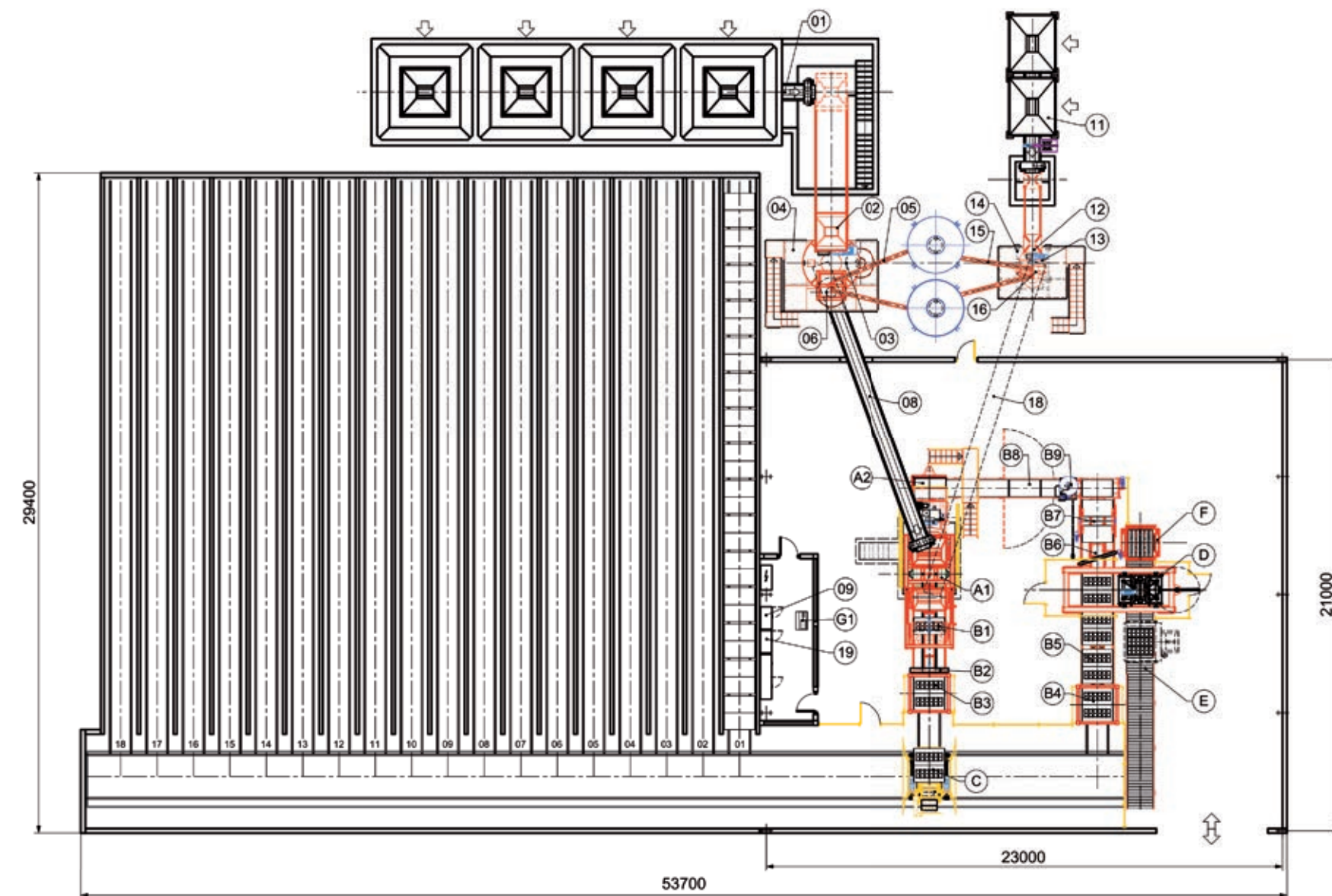



**Technical Data:**

- Product height: 25 - 400 mm (1.2" - 16").
- Production area required (for equipment and curing chambers): 1500 sq.m. (16 200 sq.ft.).
- Customized software program:
  - Touch screen for easy, visually aided operation control.
  - Memory bank for easy storage and retrieval of operational as well as historical production data.
  - Online support service, allowing for remote access to the program and easy trouble shooting.

**Vibration:**

- Two vibrating tables.
- Lubricated by permanent immersion in oil bath (minimum maintenance).
- Variable vibration (frequency and amplitude) by push of a button. Maximum vibration force: 200 kN.
- Power: 60 HP (45 kW).

**Hydraulic Unit:**

- Air cooled.
- Driven by two motors of 60 PH (45 kW) to facilitate higher speed of the machine movements.

**MEGABLOC,**  
*the machine with the highest  
production capacity in the market*

MEGABLOC stands out for providing the highest productivity in the market 18 block of 20 cm (8") per cycle (up to 4500 blocks per hour) thanks to its modular, patented vibration system with two individually adjustable vibration tables. Everything is driven by a single 60 HP (45 kW) motor which - in conjunction with our unique, programmable agitator grid - allows for a balanced filling of the mould. The system includes an electronic encoder allowing for exact control of vibration frequency and amplitude and is extremely reliable, fast and efficient. Besides, it is easy to operate and requires minimal maintenance.

The MEGABLOC machine can run on either wood, steel, or plastic boards, ranging from 1200 to 1500 mm (47 to 59") in width and from 1100 to 1500 mm (43" to 59") in depth.

Optionally, it can also be equipped to manufacture face mix product.

Handling and transport of the production boards is done by a finger car that can be customized in terms of height, load, turning capacity and operating speed.

The MEGABLOC line also includes an automatic, electronic cuber with double columns that allows for:

- High speed of the lateral and up & down movements.
- Independent clamping from both sides, programmable for each product and ensuring optimal product handling.

MODEL	MAXIMUM* PALLET'S SIZE (mm)	USEFUL PRODUCTION AREA	CYCLE TIME** (sec.)	CYCLE PARTS			PRODUCTION PER HOUR***		
				PAVERS 10X20 (pcs)	BLOCKS 15X20X40 6"	BLOCKS 20X20X40 8"	PAVERS (single layer) 10X20 (sqm)	BLOCKS 15X20X40 6"	BLOCKS 20X20X40 8"
MEGABLOC	1.400 x 1.350	1.300 x 1.300	14	66	21	18	370	5.400	4.629

\* The size of the production pallets (wooden, steel or plastic) may be tailored according to the requests of each project.  
 \*\* The cycle time is for guidance only and may vary depending on the type of product, quality of the aggregates, staff and other factors related to the production.  
 \*\*\* The hourly production is for guidance only and it is calculated at 100% of the capacity of each machine.

## Concrete batching plants, for turn-key projects

As a "turn-key" provider POYATOS also manufactures complete batching plants. These can include silos, weigh and transport belts, skip hoists as well as turbo, planetary and turbo-planetary mixers with capacities ranging from 200 to 4500 litres (25 to 6 cu.yd.) to match the consumption rate of our production machines.



MODEL MF	LOAD CAPACITY LITERS	PRODUCTION PER MIX m <sup>3</sup>	POWER	POWER OF SKIP
MF - 500	500	0,35	15 kW	4 kW
MF - 750	750	0,50	22 kW	5,5 kW
MF - 1125	1125	0,75	30 kW	7,5 kW
MF - 1500	1500	1,00	37 kW	11 kW
MF - 2250	2250	1,50	55 kW	15 kW
MF - 3000	3000	2,00	75 kW	22 kW
MF - 3750	3750	2,50	90 kW	30 kW
MF - 4500	4500	3,00	110 kW	30 kW

MODEL MP	LOAD CAPACITY LITERS	PRODUCTION PER MIX m <sup>3</sup>	POWER	POWER OF SKIP
MP - 200	200	0,15	4 kW	2,2 kW
MP - 500	500	0,35	11 kW	4 kW
MP - 1125	1125	0,75	30 kW	7 kW
MP - 1500	1500	1,00	37 kW	11 kW
MP - 2250	2250	1,50	55 kW	15 kW
MP - 3000	3000	2,00	75 kW	22 kW
MP - 3750	3750	2,50	90 kW	30 kW



## Poyatos

*special equipment: added value and innovation for your concrete products*

Besides production machinery, batch plants and handling equipment Poyatos also manufactures a wide range of machinery and systems for special products and product finishes.

All our speciality machines can be geared to varying automation levels answering to the specific needs of our clientele. They include:

- Splitters (up to 18 cuts per minute).
- Aging and bush-hammering machines.
- Shot-blasting lines.
- Colour dosing and mix systems.
- Equipment for the production of insulation blocks.
- One and two directional core pullers for production of erosion control blocks and retaining wall stones.
- Humidity control systems etc., etc.

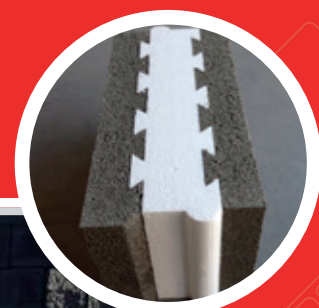

Aging and Bush-hammering line.

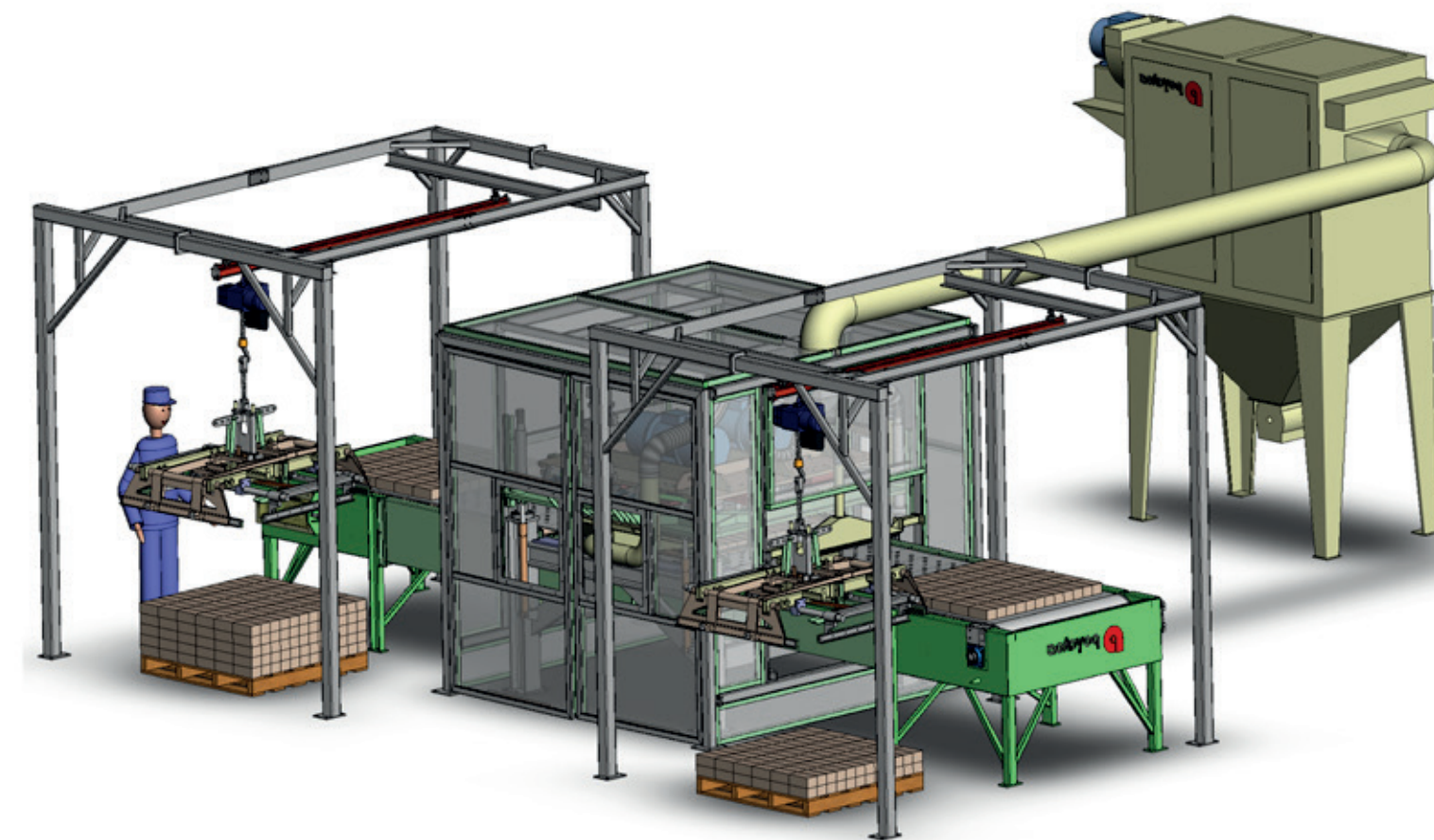

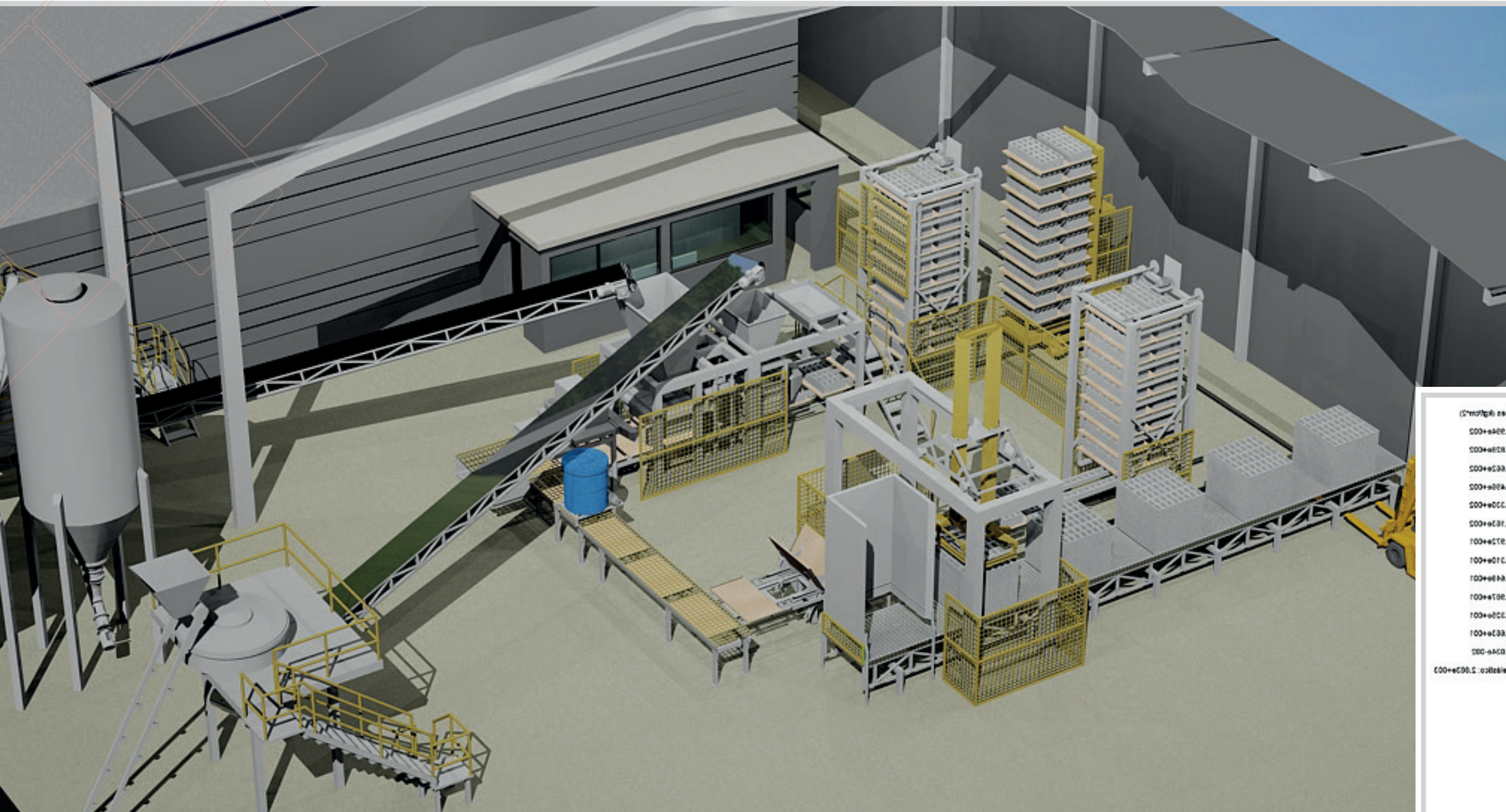

*Poyatos has the technical wherewithal to develop and manufacture personalised solutions specifically adapted to the manufacturing and marketing need of our varied and international clientele.*

Call us when you have specific projects. Our team of engineers will meticulously analyse your needs and then come forward with the best possible – and very often highly economical and ingenious – solution to the problem at hand.

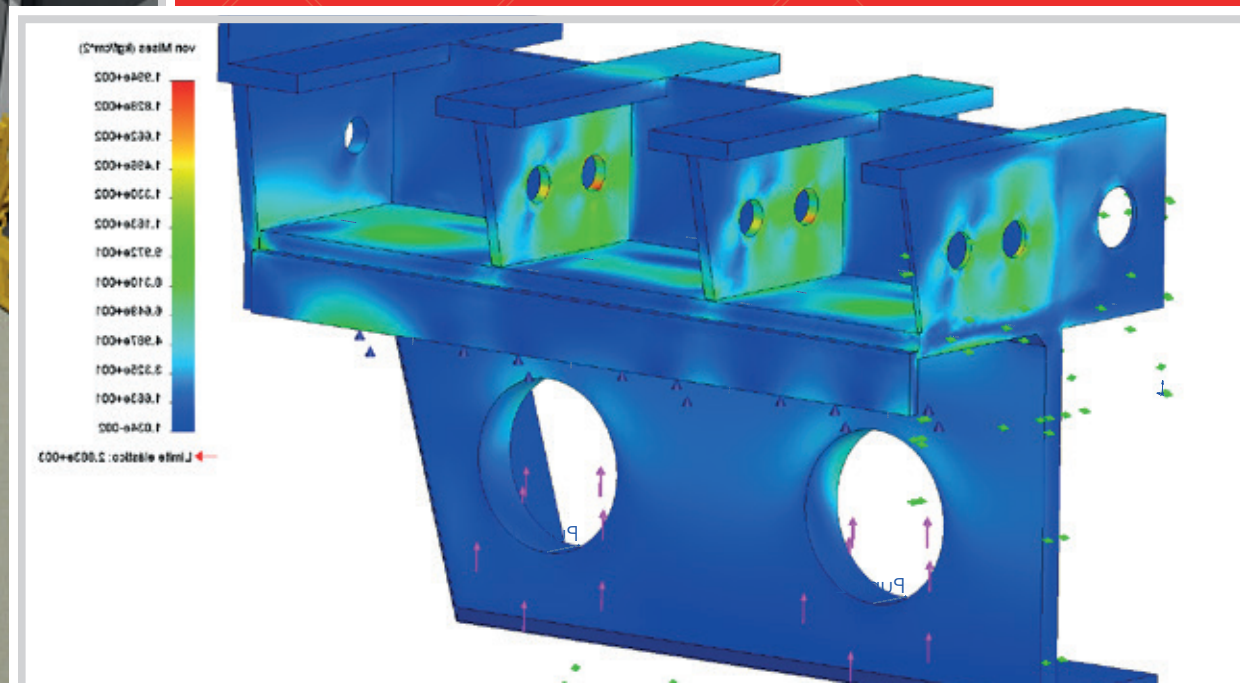

*Each and every Poyatos machine can produce any and all kind of concrete products*

**Such as:**

- Pavers and Slabs.
- Curb stones and edging products.
- Retaining wall stones.
- Erosion control blocks.
- Masonry product.
- Insulation and floor blocks.
- Bricks.
- Decorative elements, etc.

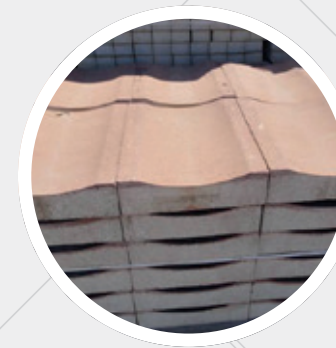
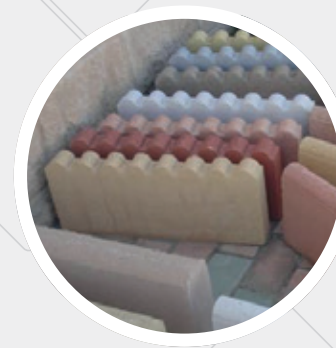
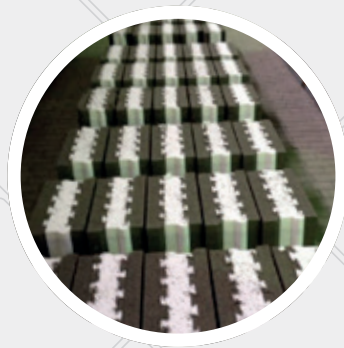
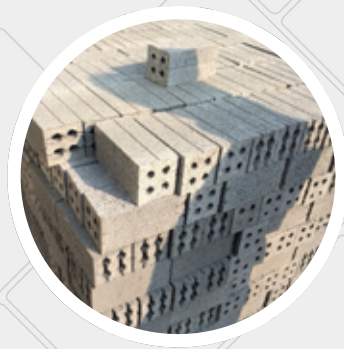
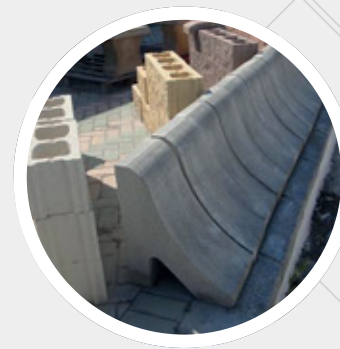



## **Poyatos** an excellent after-sales service

**The moment you purchase a Poyatos machine we become your partner for the whole, long life of our machine. We want to offer you the very best after sales service available on the market.**

To achieve this goal we put at your disposal:

- A vast stock of parts made for and by us. These parts are stocked both by our agents and representatives in the countries we sell to as well as by ourselves.
- The original references of the components we do not manufacture ourselves to allow you to source them with local distributors if you so wish.
- A specialized staff to provide technical support, either located in the country we sell to or available within 24 hours.
- Technical telephone support and operating manuals available in all major international languages (Spanish, English, French, Russian...)
- Online support on a 24/7 basis, 7 days a week.

In addition, Sales offices around the world, with experienced representatives and highly trained service staff together with an exhaustive local stock of parts supplement and enhance our unequivocal guarantee of service to you.

**Wherever our customers may be and whenever they need our support, we are at their disposal: Around the Clock and Across the Globe!**

*¡Come and visit our factory!*



+34 958 466 990 - [poyatos@poyatos.com](mailto:poyatos@poyatos.com)

Pol. Industrial Juncaril. C/ Loja 119, 18220 Albolote, Granada - Spain